

# Product Instructions

viEGA

## ViEGA® 0-10V Powerhead for 1¼" Stainless Manifold

The ViEGA 0-10V powerhead is a thermo-electric powerhead that mounts on the return valve of a ViEGA 1¼" stainless manifold. A 24-volt signal powers the unit open while controlled by a 0-10V DC signal, usually from either a thermostat or a central DDC building management system. This powerhead is compatible with 1¼" stainless manifolds of either shutoff/balancing or shutoff/balancing flow meter types.

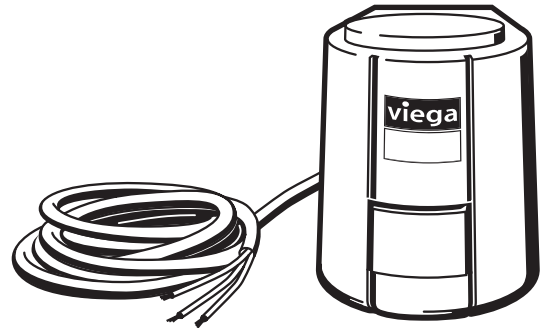

Part Number 15068

### Installing the powerhead

1. Remove the blue return valve cap from the return valve on the 1¼" stainless manifold.
2. Hand-tighten the adapter ring onto the return valve.
3. Install the connection cable to powerhead.  
**NOTE:** The plug end is configured so it can only be attached one way.
4. Place the 0-10V powerhead over the adapter ring and push downwards. The powerhead will snap onto the adapter ring. The powerhead can be installed in any position: vertically, horizontally or upside down.
5. Connect the wire ends to control unit (i.e. thermostat or building management system with 0-10V DC control signal).

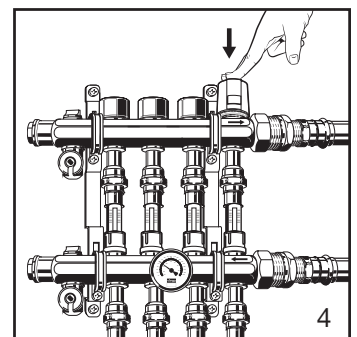
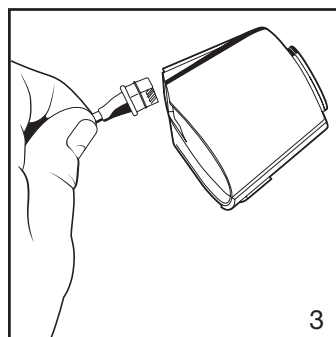
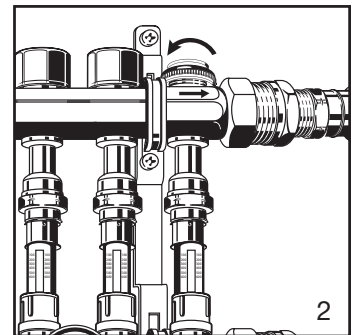
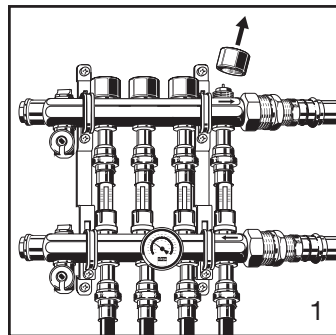

# Product Instructions

**viega**

## Wiring

1. Connect the black wire to 24 volts (typically labeled “R” on most hydronic equipment).
2. Connect the blue wire to ground (24 volt common, typically labeled “C” on most hydronic equipment).
3. Connect the red wire to the 0-10V control (usually thermostat or DDC building management system).

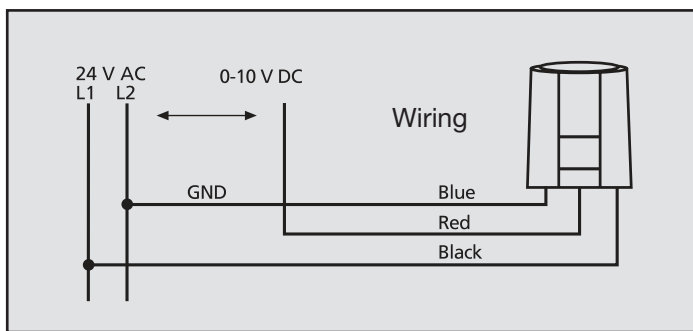

Conductor Cross Section (MM)	Substitute this American Wire Gauge
0.5	20
0.75	18
1.0	16
1.5	14
2.5	12

## Transformer sizing

Transformer Rating	Number of powerheads per transformer
40 VA	6
75 VA	12

**NOTE:** The table above is figured based on 6 W per powerhead.

## Extending the connecting cable

The powerhead cable may be extended. The length is dependent on the number of powerheads and the gauge of the wire used. The chart below lists recommendations for extending the powerhead cable.

# of 0-10V Powerheads	Length powerhead can be extended (ft)		
	20 AWG	18 AWG	16 AWG
1	134'	200'	269'
2	67'	100'	134'
3	44'	67'	89'
4	33'	50'	67'
5	26'	40'	53'
6	22'	33'	44'

**NOTE:** If your project requires something outside of what is suggested above, please use the information below for your calculations.

$$L = C \times A/N$$

L= Maximum cable run length

C= Constant (269)

A= Conductor cross section (from chart below)

N= Number of powerheads

## Dimensions

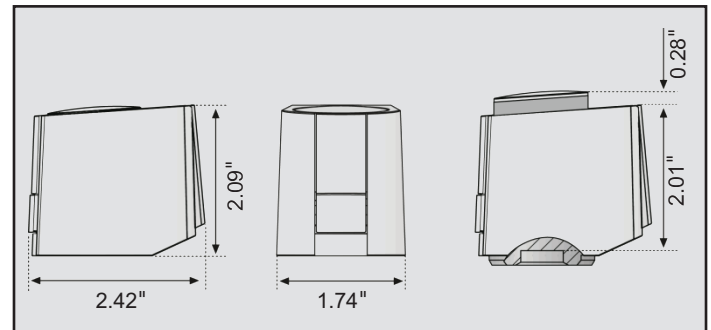

## Specifications

Voltage:	24 VAC 50/60 Hz
Control voltage:	0-10 VDC
Max inrush current:	< 320 mA during max. 2 min.
Operating power:	1 W
Actuating force:	21 lbs.
Stroke:	4 mm
Fluid temperature:	32°F - 212°F
Max pressure differential:	50 psi
Connecting cable length:	3'

# Product Instructions

viEGA

## Initially open function

The 0-10V powerhead is delivered in the open position. This allows for easier installation and allows the installer to pressure test and purge each circuit before connecting power. This function disengages automatically after 6 minutes of powered use and will return the powerhead to its normally closed position.

## Normal operation

When a control voltage of 0.5 - 10V DC is applied, the powerhead opens the valve by retracting its piston, causing the valve stem to rise. An internal optical stroke measurement controls the temperature required for the maximum stroke and, consequently, the energy use of the wax element. No excess energy is stored inside the wax element. Once the control voltage is reduced, the powerhead adapts the heat input to the wax element, allowing the integral spring to drive the valve closed. In the range of 0 - 0.5V, the powerhead remains stationary in order to ignore ripple voltage occurring in long cables.

The closing force of the compression spring is matched to the closing force of the stainless manifold, allowing the valve to stay closed when de-energized (NC).

The chart below shows the valve position based on the DC voltage applied.

**Example:** 4.5 volts applied to the powerhead would result in a 2 mm valve stroke, causing the valve to open approximately 50%.

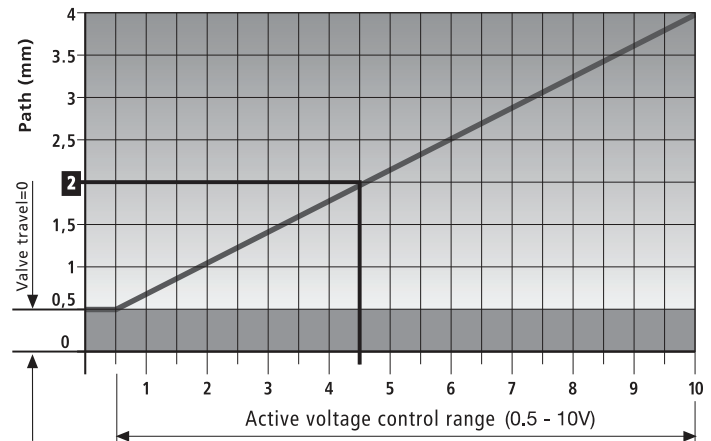

**NOTE:** The Viega 0-10V powerhead is capable of modulation. However, the 1/4" stainless manifold that it attaches to is suggested for simple two-position on/off activation.

## Open/closed indicator

The 0-10V powerhead has a cylinder on top that will raise or lower depending on the powerhead's position. When flush, it indicates that the valve is closed, and when raised, that the valve is open.

**Viega products are designed to be installed by licensed and trained plumbing and mechanical professionals who are familiar with our products' proper use and installation. Installation by non-professionals may void Viega LLC's warranty.**

This document subject to updates. For the most current Viega technical literature please visit [www.viega.us](http://www.viega.us).  
Click Services -> Click Electronic Literature Downloads -> Select Product Line -> Select Desired Document

Para ver las instrucciones en español visite [www.viega.us](http://www.viega.us) -> Services -> Electronic Literature Downloads -> French and Spanish Documents -> Documento Deseado

Pour obtenir des instructions en français visite [www.viega.us](http://www.viega.us) -> Services -> Electronic Literature Downloads -> French and Spanish Documents -> Document Désiré

**Viega LLC, 12303 Airport Way, Ste. 395 • Broomfield, CO 80021 • Ph: 800-976-9819 • Fax: 800-976-9817**